

Project

Type



Date

Product Code

Designer

MIDIMAX™ O

track mounted LED accent light



MidiMax O with Cross Baffle (OX) MidiMax O with Open Aperture (OH)



aperture view



aperture view

MidiMax O is a track mounted accent light capable of 20°, 40° or 60° beam spreads. Luminaire is powered by one of a number of Xicato LED modules, all of which are distinguished by extraordinary color consistency (within a 1x2-step MacAdam ellipse). See tables below for wattages and efficacies.

- Luminaire may be configured to mount to any of eighteen 20-amp, 120-volt [track systems](#) – or – to any of six 277-volt track systems.
 - Fixture function can be changed with your choice of Aperture Assembly and your choice of 'twist and lock' [reflector](#).
 - Aperture Assembly / Reflector choices
 - Cross Baffle (OX) for enhanced glare control ; for use with interchangeable 20°, 40° and 60° reflectors.
 - Open Aperture (OH) for maximum efficacy; for use with interchangeable 20°, 40° and 60° reflectors.
- Fixture is ordered with a single Aperture Assembly and a single reflector. Additional aperture assemblies and reflectors may be ordered as accessories.
- **Optical Accessories:** Both OX and OH Aperture Assemblies accept one or two of a number of spread lenses or color filters. With the OX assembly lens orientation may be adjusted by rotating the cross baffle. A complimentary beam smoother is included with either assembly.
 - A concealed swivel provides 385° horizontal rotation and vertical adjustment from 0° to 90°. The swivel is permanently tensioned, allowing the luminaire to remain fixed at any aiming angle.
 - MidiMax luminaires have seamless aluminum housings and cast aluminum tops for lightweight durability and heat dissipation.
 - For more information, [click here](#).

For an outlet box mounted model, see [MidiMax O-OBM](#)

PRODUCT CODE

For complete product code, list basic unit and select one item from each following box.

Basic Unit	LX2-XTM
Track Configuration	
120-volt track (e.g. SightLine)	- 2C
277-volt track (e.g. HighLine)	no switch; not dimmable - HC
Aperture Assembly	
Cross Baffle	- OX
Open Aperture	- OH
Beam Spread Reflector (specify one to ship with fixture)	
20° spot	- 20D
40° flood	- 40D
60° wide flood	- 60D
Finish	
white paint finish	- WH
black paint finish	- BL
Industrial Silver paint finish	- SI
custom color paint finish... include paint number or physical chip with order ..	- CC

Driver	
dimmable to 10% (see Light Output box below) with electronic low voltage (ELV) dimmer on 120-volt track	- DME
dimmable to 5% (see Light Output box below) with either incandescent or electronic low voltage (ELV) dimmer on 120-volt track	- DMP
non dimmable: the only choice for 277-volt track; may be selected for 120-volt track as well	- UNV
For a model that dims wirelessly; see MidiMax O Bluetooth	
For a model with an integral dimmer; see IDM MidiMax O	

Light Source Output	
1000 lumens / CRI 98 Artist	DMP [5%] -L10A
1400 lumens	DMP [5%] - L14A
2100 lumens	DME [10%] - L21A
1500 lumens / CRI 80+ standard.....	DMP [5%] -L15S
2100 lumens	DMP [5%] -L21S
1500 lumens / CRI 80+ Vibrant..... 3000K only.....	DMP [5%] -L15V
2100 lumens	3000K only.....DMP [5%] -L21V

Light Color	
2700 K	- 27K
3000 K	- 30K
3500 K	- 35K
4000 K	- 40K

OPTIONS *Specify by adding to the product code.*

a rocker type on/off switch on fixture top, for use on 120-volt track only.....	- SW
<i>white switch for white fixture, black for Silver or black fixture, specify which for custom color fixture</i>	

EXTRA APERTURES & REFLECTORS

Specify as separate line items.

Aperture Assembly	
Cross Baffle	RK-LX-OX
Open Aperture	RK-LX-OH
Reflector	
20° spot	RK-LX-XTM-REF-D20
40° flood.....	RK-LX-XTM-REF-D40
60° wide flood	RK-LX-XTM-REF-D60

OPTICAL ACCESSORIES ▼ *See next page*



OPTICAL ACCESSORIES

Specify as separate line items.

All are 3 3/4" (95mm) dia. Lenses and filters are glass; screens are aluminum.

55° spread lens	LENS/3.75
40° x 70° spread lens	LENS/3.75-4070
prismatic lens (Solite)	PLS/3.75
beam smoother included with fixture	CLR/3.75
color filters	
Daylight Blue	DAY/3.75
Surprise Pink	PNK/3.75
amber	AMB/3.75
blue	BLU/3.75
green	GRN/3.75
red	RED/3.75
33% light reduction screen	SCR33/3.75
50% light reduction screen	SCR50/3.75

MODIFICATIONS AVAILABLE

Contact factory with quantity for pricing; orders may require shop drawing approval.

For modified stem lengths up to 72", add the following to the end of the product code:
+ number of inches.

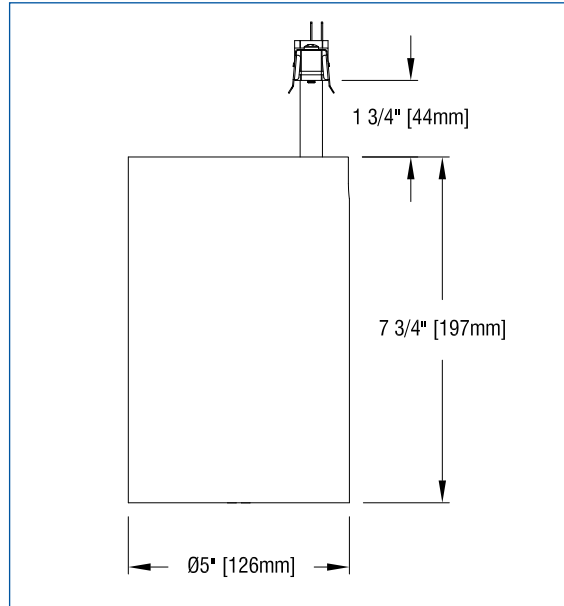

APPLICATIONS

Luminaire is suitable for highlighting vertical or horizontal surfaces, as well as objects in museums, galleries, showrooms, residences, offices and stores.

Luminaire is listed for mounting on Edison Price Lighting 120-volt or 277-volt track.

– see below for photometric reports –



PHOTOMETRIC REPORT with 20° reflector (tested per IESNA LM-79-2008)



UL Verification Services Report No. 1164149. Original test report furnished upon request.

Luminaire track-mounted LED accent light with a 20° reflector and black cross-baffle (NO LENS)

Lamp Xicato XTM LED Module, 2100 lumens, 3000K

Lamp Life rated 50.000 hours based on L70/B50 criteria. LM80 report by LED manufacturer furnished upon request

CANDLEPOWER DISTRIBUTION

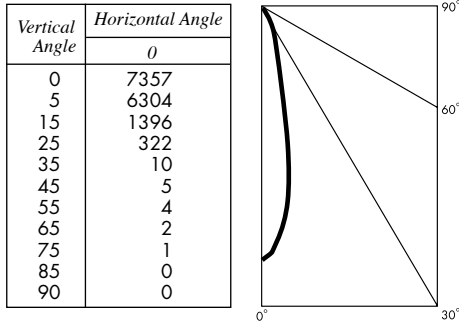

LUMINAIRE LIGHT OUTPUT AND EFFICACY

LED Module Type	Luminaire Light Output	Luminaire Efficacy (lms/watt)	System Wattage
1000 Lumens Artist	502*	37*	14
1400 Lumens Artist	722*	34*	21
2100 Lumens Artist	1072*	41*	26
1500 Lumens standard & Vibrant	801*	45*	18
2100 Lumens standard & Vibrant	1072	47	23

*estimated values

PHOTOMETRIC REPORT with 40° reflector (tested per IESNA LM-79-2008)



UL Verification Services Report No. 1164150. Original test report furnished upon request.

Luminaire track-mounted LED accent light with a 40° reflector and black cross-baffle (NO LENS)

Lamp Xicato XTM LED Module, 2100 lumens, 3000K Lamp Life see above

CANDLEPOWER DISTRIBUTION

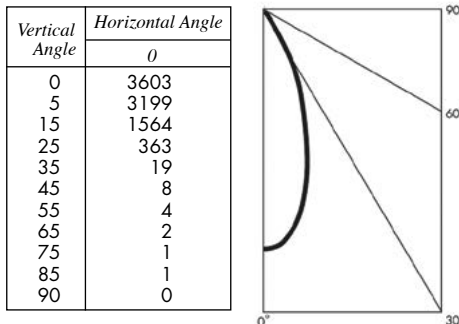

LUMINAIRE LIGHT OUTPUT AND EFFICACY

LED Module Type	Luminaire Light Output	Luminaire Efficacy (lms/watt)	System Wattage
1000 Lumens Artist	428*	31*	14
1400 Lumens Artist	615*	29*	21
2100 Lumens Artist	914*	35*	26
1500 Lumens standard & Vibrant	683*	38*	18
2100 Lumens standard & Vibrant	914	40	23

*estimated values

PHOTOMETRIC REPORT with 60° reflector (tested per IESNA LM-79-2008)



UL Verification Services Report No. 1164151. Original test report furnished upon request.

Luminaire track-mounted LED accent light with a 60° reflector and black cross-baffle (NO LENS)

Lamp Xicato XTM LED Module, 2100 lumens, 3000K Lamp Life see above

CANDLEPOWER DISTRIBUTION

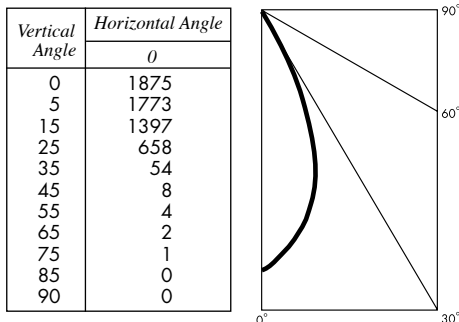

LUMINAIRE LIGHT OUTPUT AND EFFICACY

LED Module Type	Luminaire Light Output	Luminaire Efficacy (lms/watt)	System Wattage
1000 Lumens Artist	427*	31*	14
1400 Lumens Artist	614*	29*	21
2100 Lumens Artist	912*	35*	26
1500 Lumens standard & Vibrant	682*	38*	18
2100 Lumens standard & Vibrant	912	40	23

*estimated values

PHOTOMETRIC REPORT with 20° reflector (tested per IESNA LM-79-2008)

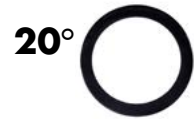

UL Verification Services Report No. 1164146. Original test report furnished upon request.

Luminaire track-mounted LED accent light with a 20° reflector and black lens holder (NO LENS)

Lamp Xicato XTM LED Module, 2100 lumens, 3000K

Lamp Life rated 50,000 hours based on L70/B50 criteria. LM80 report by LED manufacturer furnished upon request

CANDLEPOWER DISTRIBUTION

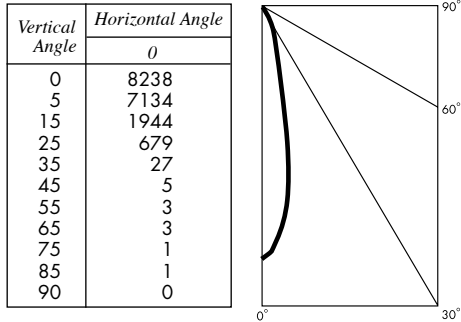

LUMINAIRE LIGHT OUTPUT AND EFFICACY

LED Module Type	Luminaire Light Output	Luminaire Efficacy (lms/watt)	System Wattage
1000 Lumens Artist	694*	51*	14
1400 Lumens Artist	997*	47*	21
2100 Lumens Artist	1480*	56*	26
1500 Lumens standard & Vibrant	1106*	62*	18
2100 Lumens standard & Vibrant	1480	65	23

*estimated values

PHOTOMETRIC REPORT with 40° reflector (tested per IESNA LM-79-2008)



UL Verification Services Report No. 1164147. Original test report furnished upon request.

Luminaire track-mounted LED accent light with a 40° reflector and black lens holder (NO LENS)

Lamp Xicato XTM LED Module, 2100 lumens, 3000K

Lamp Life see above

CANDLEPOWER DISTRIBUTION

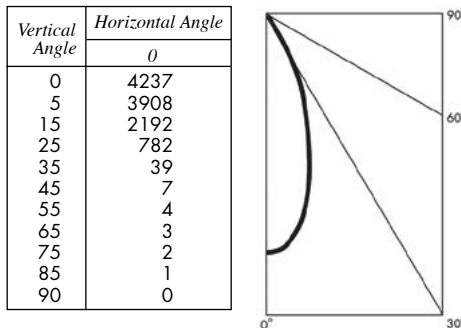

LUMINAIRE LIGHT OUTPUT AND EFFICACY

LED Module Type	Luminaire Light Output	Luminaire Efficacy (lms/watt)	System Wattage
1000 Lumens Artist	640*	47*	14
1400 Lumens Artist	920*	44*	21
2100 Lumens Artist	1366*	52*	26
1500 Lumens standard & Vibrant	1021*	57*	18
2100 Lumens standard & Vibrant	1366	60	23

*estimated values

PHOTOMETRIC REPORT with 60° reflector (tested per IESNA LM-79-2008)



UL Verification Services Report No. 1164148. Original test report furnished upon request.

Luminaire track-mounted LED accent light with a 60° reflector and black lens holder (NO LENS)

Lamp Xicato XTM LED Module, 2100 lumens, 3000K

Lamp Life see above

CANDLEPOWER DISTRIBUTION

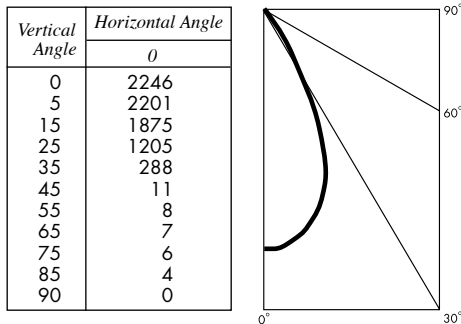

LUMINAIRE LIGHT OUTPUT AND EFFICACY

LED Module Type	Luminaire Light Output	Luminaire Efficacy (lms/watt)	System Wattage
1000 Lumens Artist	698*	51*	14
1400 Lumens Artist	1003*	48*	21
2100 Lumens Artist	1489*	57*	26
1500 Lumens standard & Vibrant	1106*	62*	18
2100 Lumens standard & Vibrant	1489	65	23

*estimated values

STANDARD DRIVER INFORMATION (UL Class 2, dry and damp location)

Voltage	120	277
Input Watts (1000A/1400A/2100A/1500/2100 lumens)	14/21/26/18/23	14/21/26/18/23
Input Current(A) (1000A/1400A/2100A/1500/2100 lumens)	.12/.18/.22/.15/.19	.05/.08/.09/.06/.08
Output Current (mA)	500-1050	500-1050
Min. Power Factor	0.90	0.90
Operating Temperature Range (F)	-13 to 122	-13 to 122

LIGHT OUTPUT MULTIPLIER

LED Module Type	Light Output Multiplier
1000 Lumens Artist	.47*
1400 Lumens Artist	.67*
2100 Lumens Artist	1
1500 Lumens standard & Vibrant	.75*
2100 Lumens standard & Vibrant	1